

LOCOLOC®

Swaging Tools

Loss Ends



#3-H

Hydraulic Handswager

Operator's Manual

LOSS CO. U.S.A.
CABLEWARE® DIVISION

CONTENTS

Title	Page
Specification	1
Part List	2
Operation Instructions	4
Refill Oil	7
Preventative Maintenance	8
Die Size	9
Warranty	10

WARNING



Read instruction manual before use.



Wear safety goggles and protective gear.



Do not use on electrical circuits.



Keep all body parts clear of swaging dies.

SPECIFICATION

Hydraulic compression tool with a two stage section for use with interchangeable die sets, 1/4 to 1/2 inch.

- Complete with plastic carrying case.
- Dies sold separately with gauges included.
- Head rotates 180° for difficult situations.



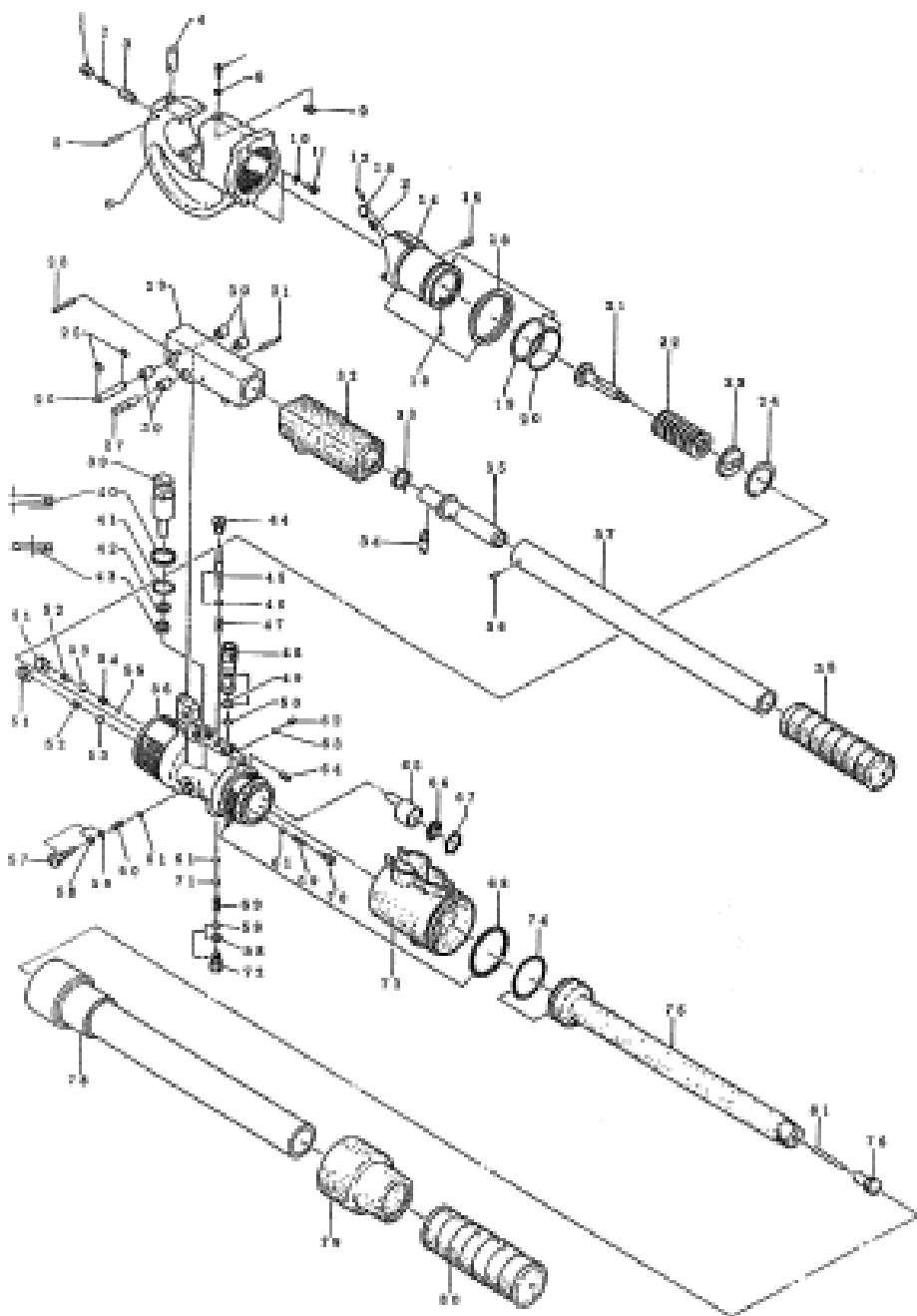

#3-H BREAKDOWN LIST

*Part list is only for reference, parts are not available for individual sale.

NO.	DESCRIPTION	CODE	QTY	NO.	DESCRIPTION	CODE	QTY
1	M10 X 10 Screw (F.P.)	16-41	1	50	P-8 O-Ring (C.P.)	410-43	1
2	Spring (177)	410-01	2	51	Valve Screw (10)	410-44	2
3	Retainer Pin (A)	410-02	1	52	Spring (67)	85-39	2
4	Die Release Pin (A)	410-03	1	53	9/32" Ball	16-40	2
5	2.5 X 25 Drive Pin (BW)	410-04	1	54	Spring (66)	85-40	1
6	Head	410-05	1	55	3/16" Ball	16-49	1
7	M4 X 10 Screw	410-06	1	56	Body	410-45	1
8	M4 Lock Washer	410-07	1	57	Suction Valve Plug	410-46	1
9	Key	410-08	1	58	P-4 Back-Up Ring (B.C.)	410-47	2
10	M5 Lock Washer	410-09	2	59	P-4 O-Ring (C.P.)	410-48A	2
11	M5 X 6 Screw	410-10	2	60	Spring (4)	16-48	1
12	2.5 X 14 Drive Pin (BW)	410-11	1	61	7/32" Ball	16-26	3
13	Retainer Pin (B)	410-12	1	62	M4 X 4 Screw (F.P.)	85-47	1
14	Ram	410-13	1	63	1/8" Ball	40-20	1
15	Die Release Pin (B)	410-14	1	64	M5 X 8 Screw	410-49	1
16	Dust Seal	430-03	1	65	Strainer	410-72A	1
18	2.5 x 8 Dowel Pin (B)	410-17	1	66	Filter Screen	410-73	1
19	P-40 Back-Up Ring (B.C.)	22-16	1	67	SI-20 Ring	410-74	1
20	P-40 O-Ring (C.P.)	410-70	1	68	G-40 O-Ring	P100A-05	1
21	Ram Spring Guide	410-18	1	69	Spring (43)	85-49	2
22	Spring (65)	410-19	1	70	Valve Screw (22)	410-80	1
23	Ram Spring Support	410-20	1	71	Spring Holder	410-51	1
24	OV-36 Snap Ring	410-21	1	72	Valve Plug (1)	410-52	1
25	CE-7 Snap Ring	40-49	2	73	Body Insulation	410-53	1
26	Pin (85)	410-22	1	74	G-30 O-Ring	75-26	1
27	Pin (84)	410-23	1	75	Oil Reservoir	410-54	1
28	5 X 32 Dowel Pin (G)	85-57A	1	76	Reservoir Cap	410-55	1
29	Pump Handle Head	410-24	1	78	Ass'y(Yellow)	410-58B	1
30	Bushing	410-25	4	79	Insulation	410-59	1
31	4 X 26 Dowel Pin (G)	410-26	1	80	Body Handle Grip	410-60	1
32	Handle Head Insulation	410-27	1	81	Magnet	ROB-25	1
33	Spring (146)	85-60	1				
34	Push Pin	85-61	1				
35	Pump Handle Stem	410-28	1				
36	3 X 8 Dowel Pin (G)	410-29	1				
37	Pump Handle	410-30	1				
38	Pump Handle Grip (2)	410-31	1				
39	Pump Piston	410-32	1				
40	P-20 X-Ring	410-33	1				
41	P-20 O-Ring (C.P.)	410-34A	1				
42	P-8 Back-Up Ring (B.C.)	85-33	1				
43	PS-8 Pent Seal	16-44	1				
44	Release Valve Screw (7)	85-35	1				
45	Release Valve Stem	410-35	1				
46	P-3 O-Ring (C.P.)	UC-27	1				
47	Spring (144)	85-37	1				
48	Bypass Cartridge	410-36	1				
49	S-9 O-Ring	410-71	1				

OPERATING INSTRUCTIONS

- 1. To insert a die in the top of the head (6).** Push the die release button (4) and place one die of the set in the top of the head, center it and release the button.
- 2. Insert the other die in the bottom of the head.** Depress the die release pin (15) and place the other die of the set in the bottom of the head and release the pin. The die will be held by the retainer pin (13). If it is difficult to depress the die release pin, pump the handle several times, this will expose the pin.

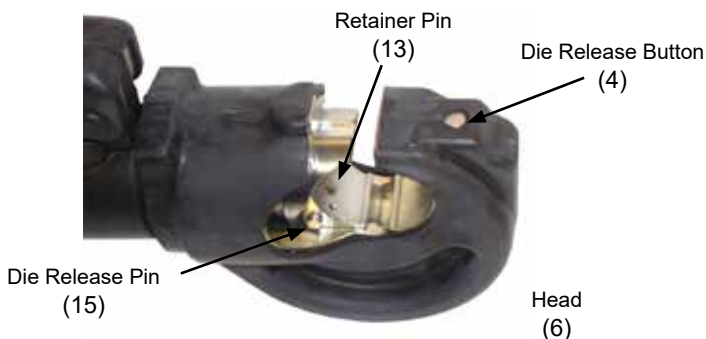

- 3. The head of the compressor will rotate 180 degrees.** The head can be rotated to any desired position to accommodate operator's view of the dies, fitting position and operation.

CAUTION:

Do not rotate the head under hydraulic pressure.

OPERATING INSTRUCTIONS (CONT.)

4. **Operate the pump handle (37)** until the dies are closed. If the dies are not clearly visible, the pumping should continue until a sound from bypass valve (48) is heard. First Stage, the pumping sound will accompany a reduction in the force required to close the pump handle.

After first stage has bypassed, pump 5 to 6 more times until it hits the second stage bypass. If the dies fail to close, it will be due to:

- a) the tool being used for some application for which it was not designed.
- b) the pressure not building up to 700kgs/cm (10,000 psi)
- c) the wrong dies being used for the incorrect size sleeve.



OPERATING INSTRUCTIONS (CONT.)

5. Release pressure after operation.

Release pressure by twisting pump handle (37) clockwise while holding the handle in the open position, then move the handle down into the closed position.

WARNING: Keep fingers clear from the dies and ram (14) during operation.



Properly swaged sleeve.

Use the gauge that is provided to check the accuracy of the after swage dimension of the sleeve. Properly swaged sleeves should pass easily into the slot that corresponds to the sleeve sizes. Sleeves that do not fit properly into the gauge slot after swaging is an indication that the tool may be out of adjustment.



REFILL OIL

1. Place the tool, head downward, and hold it in a vertical position.
2. Release pressure by twisting the handle clockwise (37) and press down.
3. Remove the body handle assembly (78 - 80)
4. Pump the handle several times and release pressure. Repeat this procedure several times. This will clear any air bubbles in the hydraulic system.
5. Holding the pump handle in the closed position, remove the reservoir cap (76) with care as air bubbles may remain in the end of the oil reservoir.
6. Fill oil (Shell Tellus oil T15, Mobile DET-13, or equal) and reset the cap.
7. Check the oil reservoir for pin holes by squeezing reservoir with fingers. If any leaks are detected, replace with a new reservoir (76).

PREVENTIVE MAINTENANCE

1. Do not pump the tool to closed jaw position when the dies are not placed in the head. This can place excessive pressure on the jaws resulting in fracture or distortion of the jaws. If the jaws are mistakenly closed without the dies, do not continue to apply pressure by further pumping. If jaws are closed without die, loosen the bypass (48) and the release (45) valve.
2. Keep the tool clean and free from dirt or metal particles, especially around the head, dies and ram (14) of the tool.
3. Check the oil level periodically and use clean oil as recommended. Never mix different brands or types of oil as deterioration of the oil seals may result.
4. Do not adjust bypass cartridge.

DIES

ALWAYS USE GAUGE TO CHECK THE AFTER SWAGE DIMENSION.

Information below for: Flexible Cable 7x19 / 6x19 Construction.

Cable Diameter	LOOS Part Number	Use die & gauge #	Sleeve	No. of compressions
1/4	HD3-8	1/4	Copper & Aluminum Oval	2
5/16	HD3-10	5/16	Copper & Aluminum Oval	2
3/8	HD3-12	3/8	Copper & Aluminum Oval	3
7/16	HD3-14C	7/16	Copper Oval	4
7/16	HD3-14A/16C	7/16	Aluminum Oval	3
1/2	HD3-14A/16C	1/2	Copper Oval	4
1/2	HD3-16A	1/2	Aluminum Oval	4

FOR MAXIMUM SAFETY AND HOLDING POWER WE RECOMMEND USING TWO(2) SLEEVES ON 3/8" AND LARGER.

WARRANTY

Huskie Tools products carry a warranty that makes us a leader in the tool industry. No other manufacturer dares to back its tools as we do.

All Huskie REC-SERIES battery-operated products carry a 5-year warranty. The ECO-SERIES battery-operated products carry a 1-year warranty. The IL-ND battery-operated products carry a 3-year warranty. The BP-70E, BP-70EI, BP-70MH, and BP-80 batteries carry a 5-year or 1,000 recharge cycles warranty from the date stamped on the battery.

PRODUCT WARRANTY

REC-Series battery-operated products	5 Years
ECO-Series battery-operated products*	1 Year
IL-ND battery-operated products	3 Years
Batteries (BP-70E, BP-70EI**, BP-70MH, BP-80)	5 Years
Chargers (CH-35R, CH-70DCH, CH-90, CH-86)	5 Years

*Please call the factory with warranty questions.

**The BP-70EI is no longer available. The LED indicator on the BP-70EI carries a 1-year warranty from purchase date.

The warranty does not cover any damages incurred from a Huskie tool including damages to property, bodily injuries, and lost wages resulting from such injuries. This warranty solely covers the repair or replacement of tools supplied by Huskie. These remedies are exclusive, and the total liability of Huskie Tools, Inc. whether based on contract, warranty, negligence, indemnification, strict liability or otherwise, shall not exceed the purchase price of the tool. In no event shall Huskie Tools, Inc. be liable for consequential, incidental or special damages.

HUSKIE TOOLS, INC. MAKES NO OTHER WARRANTIES OF ANY KIND, EXPRESSED OR IMPLIED, AND ALL IMPLIED WARRANTIES INCLUDING ANY WARRANTY OF MERCHANTABILITY AND FITNESS FOR A PARTICULAR PURPOSE ARE DISCLAIMED.

WARRANTY (CONT.)

Huskie reserves the right to determine all warranty claims. Huskie will not warranty tools containing parts or batteries not originally supplied by Huskie. Failure due to misuse, improper maintenance, misapplication, not following instructions or warnings, abuse or repairs attempted by anyone other than Huskie Tools, Inc. or an authorized service center renders this warranty null and void.

Repair and Warranty Claims

All claims must be sent to Huskie for inspection and authorization. A Return Goods Authorization (RGA) is required before shipping tools to Huskie. Secure the authorization by telephoning or writing to Huskie's main office with details of the claim. Non-warranty repairs are handled using the same procedure. Repairs exceeding 50 percent of the cost of a new tool will be advised before repairs are made.

Payment Terms

Upon credit approval, Huskie's standard payment terms are net-30 days. Visa, Mastercard, Discover, and American Express are also accepted.

Freight

All Huskie Tools are FOB, Glendale Heights, Illinois. Goods will be shipped pre-paid and added, unless otherwise specified. Freight shipments over \$17,000 are pre-paid.

Quotations

Special quantity quotations should be phoned in to discuss the scope of your tool requests.

WARRANTY (CONT.)

Complete Support Services

Our customers have direct access to us for training, service, and problem solving. As specialists in tools, we maintain a trained repair staff and a large stock of parts. This contrasts with many tool suppliers who carry tools as a sideline without offering support services. Here are some reasons why our customers love to do business with us:

- Quick delivery
- We maintain inventory in our headquarters
- Training and troubleshooting services
- Fast repair service
- Design and engineering service for special tools

HOW TO GET SERVICE UNDER THE TERMS OF THE LIMITED WARRANTY

Return your product directly to Huskie Tools, Inc. as our representative network is not prepared to service the product under the terms of this warranty.

1. Write, call, or fax Huskie stating the tool's purchase date and problem. You will be given an RGA # to assure that your merchandise will be properly handled upon its receipt.
2. CAUTION: Make sure the product is packaged adequately so as to prevent damage or loss during transit. The shipment must be prepaid and we recommend that it be insured. A cover letter indicating the reason for the return should be included in order to facilitate repairs.
3. To fill out an RGA online, go to HuskieTools.com and click on "Repairs."



198 N. Brandon Drive, Glendale Heights, IL 60139

Phone: (800) 860-6170 Fax: (800) 345-3767

HuskieTools.com



901 Industrial Blvd • Naples, FL 34104
Tel: (239) 643-LOOS • Fax (239) 643-4558
E-mail: info@loosnaples.com • Website: www.loosnaples.com